

FORNO MULTIFUNZIONE DUAL COOK FLEX™



GARANZIA

NV75N5641BS

Forno Multifunzione Dual Cook Flex™

Capacità vano cottura **75 lt**

Funzioni di cottura **68: 28 Tradizionali + 40 Automatiche**

Finitura **Inox Anti-Impronta**

Dim. Esterne (LxAxP in mm) **595x595x570**

Dim. vano incasso (LxAxP in mm) **560x572x545**

DESIGN



Out Dial

MANOPOLE
A SCOMPARSA



DISPLAY
TOUCH

FUNZIONALITÀ



DUAL
COOK



DUAL
DOOR



68
FUNZIONI
COTTURA

A+

EFFICIENZA
ENERGETICA

COMFORT

75L

GRANDE
CAPACITÀ



VANO IN SMALTO
CERAMICO



PULIZIA
A VAPORE



SICUREZZA
BAMBINI



PULIZIA
CATALITICA

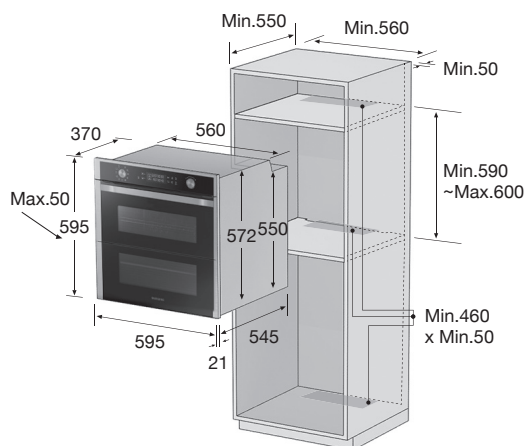
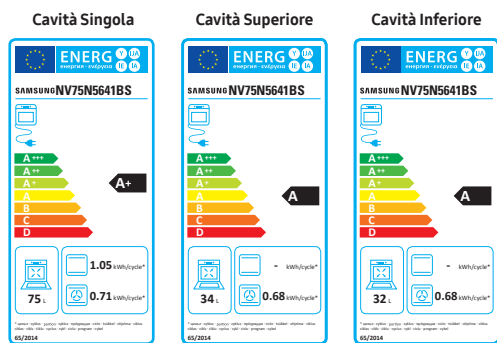

Le misure si intendono in mm



NV75N5641BS

cod. EAN TBD

SAMSUNG

SCHEDA TECNICA*

Produttore	Samsung
Codice modello	NV75N5641BS

CARATTERISTICHE FORNO

Classe Energetica	A+
Rivestimento Cavit�	Vano in Smalto Ceramico
Design	Finitura Inox Anti Impronta
Porta	
N� Vetri	2
Drop Down	•
Soft Closing	-
Lampada Interna	25W / 40W (Alogena)
Posizione Lampada Interna	Superiore / Laterale

Controlli

Altezza Display	85mm
Display	LED Ice Blue
Tipologia	Comandi Touch Screen e Manopole Pop-Up
Wi-Fi	-

Modalit  Pulizia

Pirolitica	-
Catalitica	•
Vapore	•
Grill Reclinabile	Swing

CARATTERISTICHE TECNICHE

Range Temperature

Ventilato	30~250�C
Grill Singolo	100~270�C
Superiore o Inferiore	40~250�C
Twin	40~250�C

Grill Grande	1600W / 1100W
Grill Piccolo	1100W
Ventola	1200W / 1200W
Input Power	3650~3950W
Overvoltage Security	•

MODALIT  DI COTTURA

Cavit  Intera

Modalit� Forno	
Tradizionale	30~250�C
Ventilato	30~250�C
Eco Ventilato	30~250�C
Grill Grande	100~270�C
Grill Piccolo	-
Eco Grill	100~270�C
Resistenza Inferiore + Ventilato	40~250�C
Resistenza Superiore + Ventilato	40~250�C
Resistenza Inferiore	100~230�C
Intensivo	-
Pro-roasting	80~200�C

Funzioni Speciali

Vapore + Ventilato	-
Resistenza Superiore + Vapore + Ventilato	-
Resistenza Inferiore + Vapore + Ventilato	-
Cottura Vapore	-
Cottura Vapore Assistita	-
Mantieni in Caldo	40~100�C
Piatto Caldo	30~80�C
Defrost	-

Cavit  Superiore

Lievitazione Pasta	-
Cottura Lenta	-
Essiccazione	-

Cavit  Inferiore

Funzioni Automatiche	40 EA (Twin Mode 10 EA)
Funzione Salvataggio Preferite	-
Ventilato	40~250�C
Resistenza Superiore + Ventilato	40~250�C
Grill Grande	200~250�C
Eco Ventilato	40~250�C
Resistenza Inferiore	100~230�C
Resistenza Inferiore + Ventilato	40~250�C
Cottura Vapore	-
Cottura Vapore Assistita	-

Entrambe le Cavit� Simultaneamente Cavit� Superiore x Cavit� Inferiore	3 Mode x 3 Mode = 9 EA
---	------------------------

CONTROLLI

Orologio	•
Sicurezza Bambini	•
Timer	•
Selezione Tempi di Cottura	•
Selezione Fine Cottura	•
Opzioni Lingua	-
Suono	•

DIMENSIONI

Dimensioni (L x A x P)

Esterne	595 x 595 x 570 mm
Incasso	560 x 572 x 545 mm
Imballo	694 x 660 x 660 mm

Capacit 

Volume Netto	75 L
Volume Netto (Cavit� Superiore / Inferiore)	34 / 32 L
Peso Netto	41.7 Kg